

# Small Wind 101: An Overview of Small-Scale Wind Electric Systems

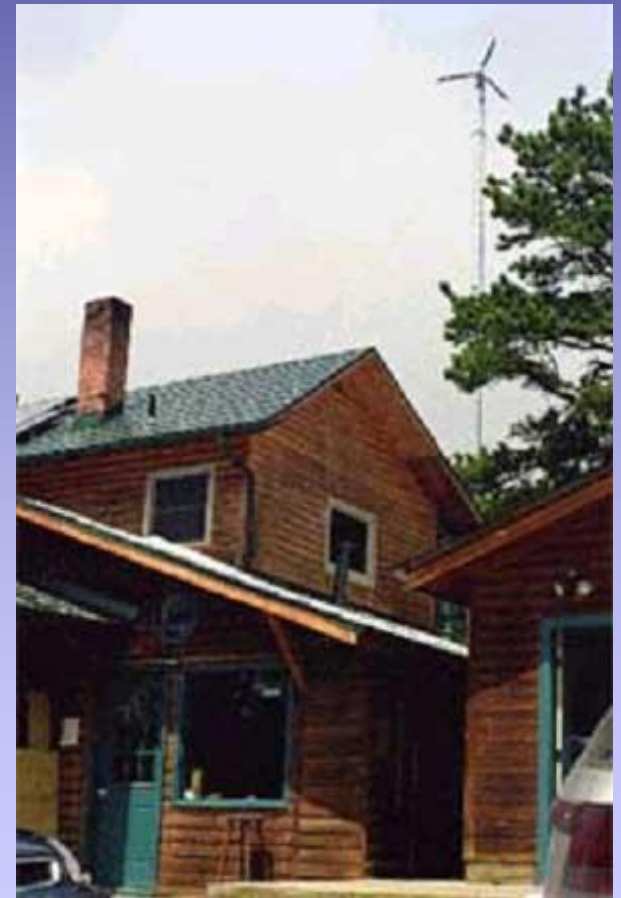

***Affordable,  
Clean Energy  
for Homes, Farms  
& Businesses***



# Why Wind?

- **Gain energy independence**
- **Ease demand on the power grid**

- **Reduce vulnerability to volatile utility prices**
- **Reduce air pollution from fossil electricity sources**



# A Valuable, Widely-Available Resource

## Small Wind Energy Systems

Value of Power =  
6-18¢ / kWh

Installed cost of \$2-\$3/Watt is 1/3 to 1/2 that of solar technologies

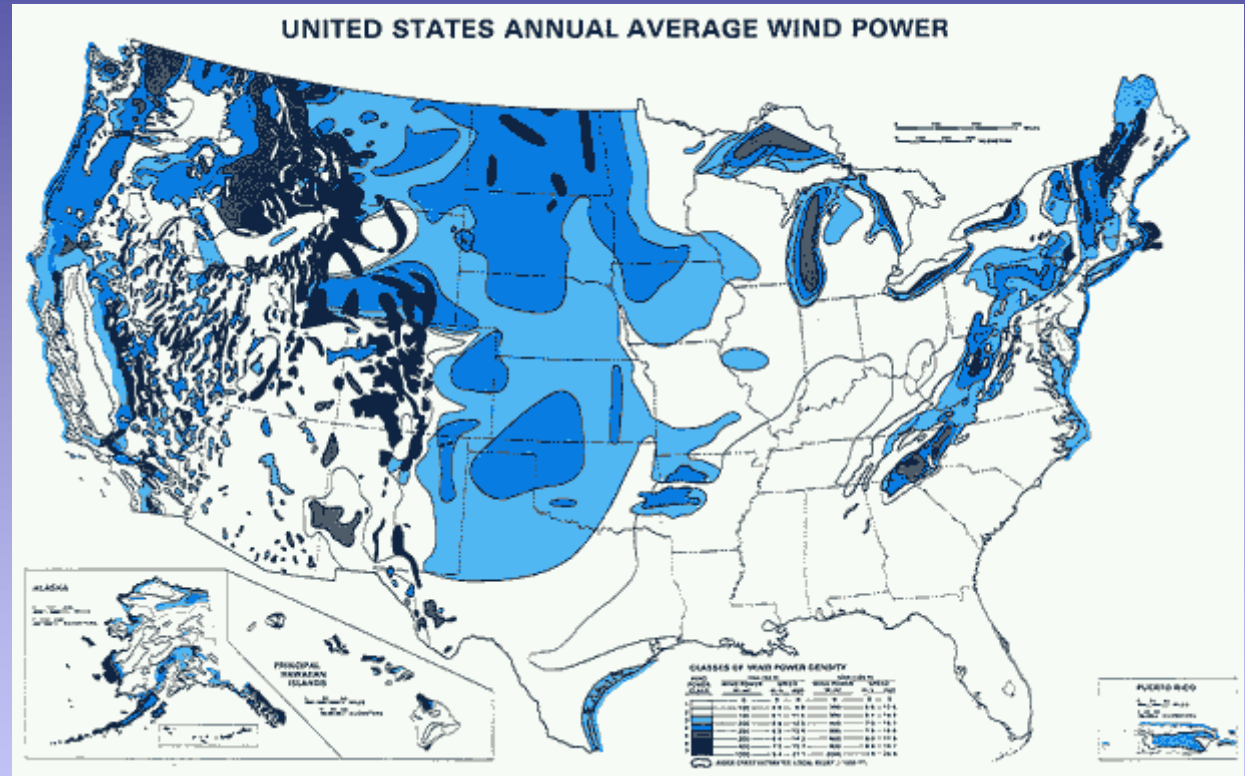

Require less wind to operate than utility-scale wind energy applications

# How Small Wind Turbines Work

**Wind Turbine**  
(400 W-100 kW)

**Guyed or  
Tilt-Up Tower**  
(60-120 ft)

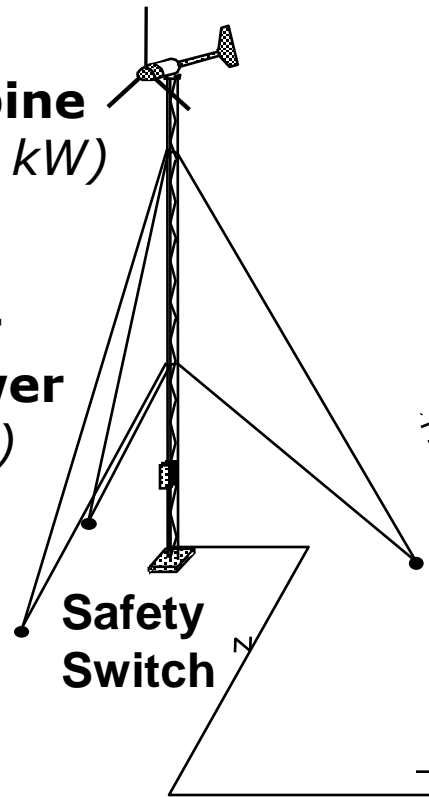

**Safety  
Switch**

**Basic Parts of a Small  
Wind Electric System**

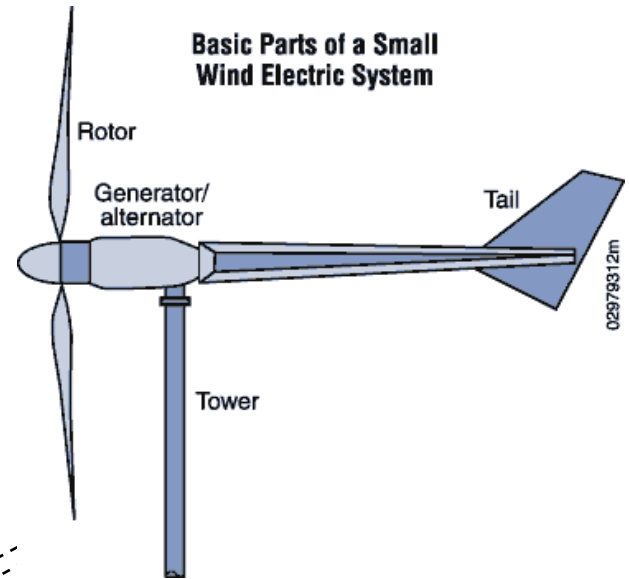

Rotor

Generator/  
alternator

Tail

Tower

02979312m

**Cumulative  
Production Meter**

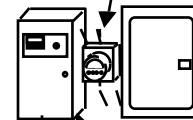

**AC Load Center**

**Power Processing  
Unit (Inverter)**

# Typical Applications

## *Farms, Homes, Businesses*

### Off-Grid Water Pumping with Wind



- Supplies water for 120 head of cattle
- 1 kW, 9-ft rotor, 30-ft tower
- Produces ~ 2,000 kWh/yr
- Offsets ~ 1.5 tons CO<sub>2</sub>/yr
- Costs ~ \$4,000 installed

### Supplementing Grid Power



- Connected to utility grid through house/farm wiring
- 3 kW, 15-ft rotor, 23-ft tower\*
- Produces ~ 5,000 kWh/yr
- Offsets ~ 3.8 tons CO<sub>2</sub>/yr
- Costs ~ \$10,000

*\* due to zoning restrictions  
(not recommended)*

# Typical Applications

## *Farms, Homes, Businesses*

### Offsetting All Utility Power



- “Net metering” utility power
- 10 kW, 23-ft rotor diameter, 100-ft tower
- Produces ~ 15,000 kWh/yr
- Offsets ~ 14 tons CO<sub>2</sub>/yr
- Costs ~ \$35,000

### Selling Power Back to Utility



- Excess power sold to utility
- 50 kW, 49-ft rotor, 90-ft tower
- Produces ~120,000 kWh/yr
- Offsets ~ 91 tons CO<sub>2</sub>/yr
- Costs ~ \$150,000

# Frequently-Asked Questions

- Will the noise bother my neighbors?
- What about visual impact?
- Do wind turbines kill birds?
- Will it interfere with TV/radio reception?
- Can wind supply power during an outage?
- What happens during a tornado?

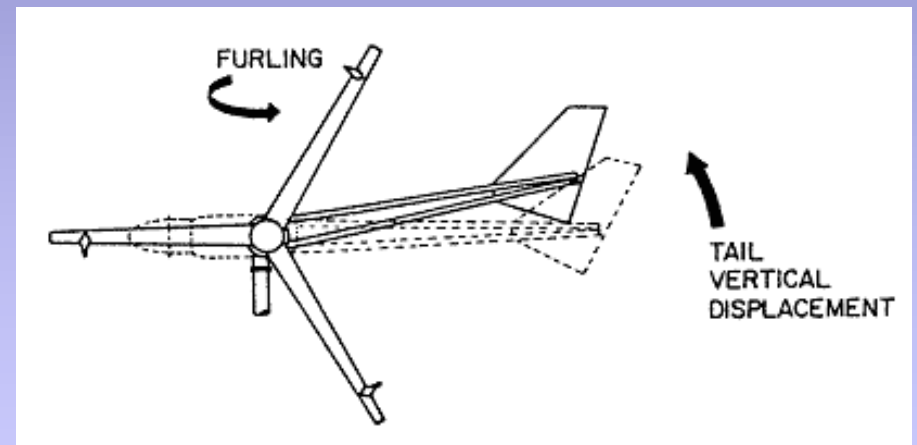

*Side furling: rotor turns to the side during extreme winds*

# Factors to Consider



- **Good wind resource: Class 2 or better**
- **Home or business located on 1 acre or more of land**
- **Average monthly electricity bills  $\geq$ \$100 for 10 kW system,  $\geq$ \$50 for 5 kW system**
- **Zoning restrictions, economic incentives**

# Options: On or Off the Grid?

## Stand-Alone System



- **Batteries to store excess power**
- **Charge controller**
- **Inverter (DC to AC)**
- **Back-up power source for complete energy independence**

## Grid-Connected System



- **Inverter (DC to AC)**
- **Annual wind speed  $\geq 10$  mph (4.5 m/s)**
- **Customer motivated by high utility prices, self sufficiency, or environmental concerns**

# Net-metering for Grid-Connected Systems

- “Bank” excess energy with the local utility
- Meter spins backward; customer receives full retail value for each kWh produced
- Net excess generation (NEG) credited monthly or annually



# Modern Small Wind Turbines

*High Tech, High Reliability, Low Maintenance*

- Small turbines range from 20 W to 100 kW
- Only 3-4 moving parts means very low maintenance
- 20- to 40-year design life
- Proven technology – 150,000 installed; over a billion operational hours
- American companies are the market and technology leaders
- Substantial cost-reduction potential

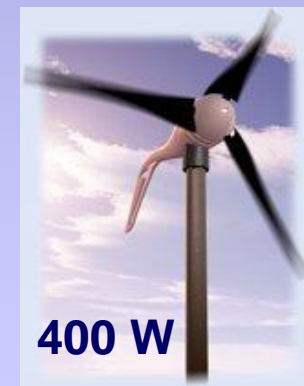

*(Not to scale)*

# Historic Barriers to Small Wind Energy Systems

- **Economics: Low production volume & historical lack of public funding = high costs**
- **Small wind upstaged by large-scale projects and other technologies**
- **Zoning / Permits: 35-ft height restriction in residential zones, noise, NIMBY attitudes**
- **Onerous interconnection requirements**
- **Low public awareness**



# New Technology is Lowering Costs

## U.S. DOE's Advanced Small Wind Turbine Program + industry-funded R&D

- Advanced airfoils
- "Super-magnet" generators
- Low cost manufacturing
- Smart power electronics
- Very tall towers
- "Stealth" low noise & visual impact

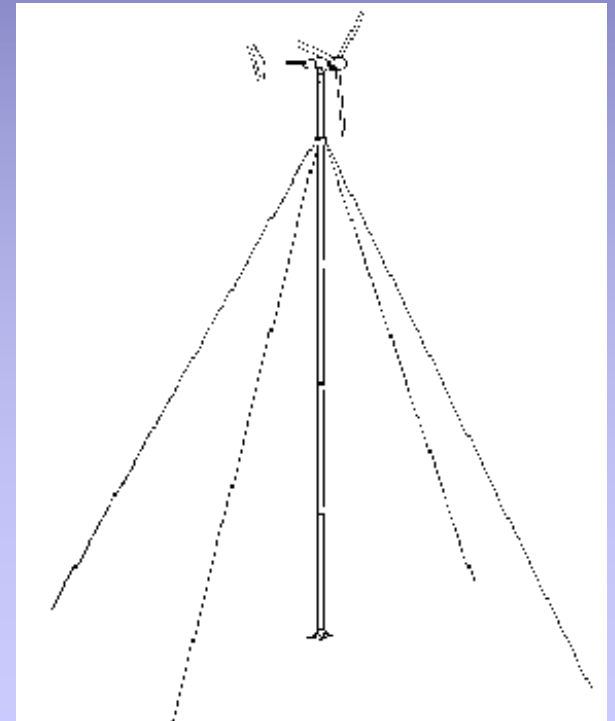
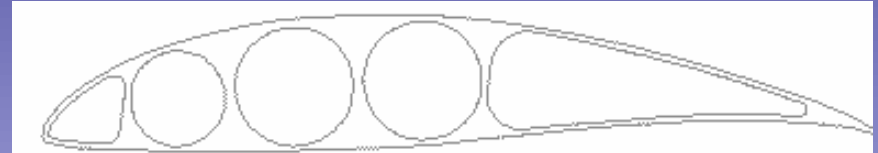

# Programs and Policies to Nurture the Rural Residential Market

- Buy-down, rebate or grant programs
- State production tax credits
- Sales and property tax exemptions



- Net metering, with annual “banking” period
- Reasonable interconnection standards
- Model zoning ordinances

# ***Sources for Further Information on Small Wind***

- **American Wind Energy Association**  
Washington, DC 202-383-2500  
[www.awea.org/smallwind.html](http://www.awea.org/smallwind.html)
- **U.S. DOE National Wind Technology Center**  
Boulder, CO Clearinghouse: 800-363-3732  
[www.nrel.gov/wind/smalltur.html](http://www.nrel.gov/wind/smalltur.html)  
[www.eren.doe.gov/erec/factsheets/wind.html](http://www.eren.doe.gov/erec/factsheets/wind.html)  
[www.eren.doe.gov/power/consumer/](http://www.eren.doe.gov/power/consumer/)
- **Home Power Magazine**  
Ashland, OR 800-707-6585  
[www.homepower.com](http://www.homepower.com)

